

# VOLKAN

## SKID-STEER LOADERS



**PSD** PSD HEAVY  
INDUSTRIES CO., LTD.

**VOLKAN PSL Series 150D & 180D & 190D** [www.psdheavy.com](http://www.psdheavy.com)



**BUILD YOUR  
WORK SOLUTION**

# **ON VOLKAN PERFORMANCE**

Even in extreme environments, the Volkan Skid loader can perform tasks with high efficiency.

A higher-than-equivalent load capacity will be highly competitive in the construction site, And with high hydraulic capacity, various attachments can be installed to complete all work on road pavement in a short period of time. Volkan Skid loader will be the best solution when you run your farm.

# VOLKAN

SKID-STEER LOADERS



# FAST, EASY, STRONG CRAZY MONSTER

Volkan skid loaders will dramatically increase work efficiency with high quality, durability, and performance.



# PERFORMANCE

## HIGH DURABILITY AND REDUCED MAINTENANCE COSTS

In fact, various performance tests were conducted in alpine, tropical, and cold climates to minimize quality problems, and maintenance costs can be reduced due to longer fuel and oil filter cycles compared to the same level.



### Reduced fuel costs

Low fuel consumption by building an optimized combustion system.

### Powerful Output

The high output allows you to easily work on a large amount of work even in rough working environments.



### Danfoss Hydraulic System

The HST pump, gear pump, and driving motor are all made of Danfoss products so compatibility and setting between products are perfect. It has the best work power with high quality and durability and has built a hydraulic system suitable for using various attachments.



### Tsubaki Chain

Made of heavy-duty steel, the Tsubaki chain does not require seasonal tension control and is durable and can be used semi permanently.



### High strength integrated frame

High-tension steel plates are used through structural analysis to protect internal functionality with a solid integrated welding structure and to design the safety of the driver as a top priority.

# VOLKAN

SKID-STEER LOADERS



MAKE MULTIPLE TASKS EASIER

# THE BEST FEATURES



**VOLKAN**  
SKID-STEER LOADERS



## A LONG AXIAL DISTANCE

Reduced rolling phenomenon during equipment operation due to long axial distance. Reduced stability and driver fatigue during driving.



## WIDE WHEELBASE CLEARANCE

Increased operational and operational stability with a wide wheelbase compared to the same level.



## HYDRAULIC QUICK COUPLER

It is equipped with a pressure control valve, so you can easily adjust the pressure when exchanging the attachment.



## HIGH-FLOW

If you select the High flow option, the addition of an auxiliary hydraulic pump provides high flow performance. If you are using an attachment such as Cold Planer or Wheelsaw, select the High-flow option.

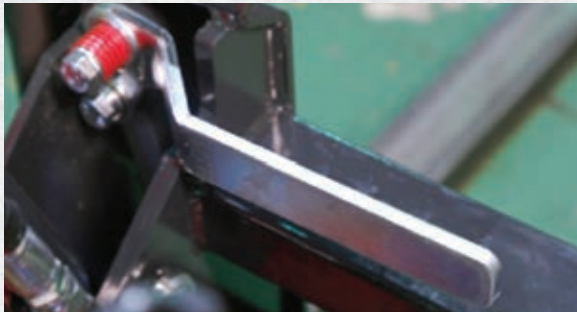

## ONE-TOUCH LEVER

You can easily attach and detach the attachment with a one-touch lever.



## LED LIGHTS

LED Lights are installed as a standard, so it is easy to secure visibility during night work.

SAVES YOUR TIME, TAKE A REST

# OPTIMIZED CONVENIENCE



**VOLKAN**  
SKID-STEER LOADERS



### REAR CAMERA

Rear camera and monitor have been added to improve visibility.



### AIR CONDITIONER

Options to improve work efficiency by maintaining a pleasant environment with smooth air circulation



### HYDRAULIC JOYSTICK

Driving and boom operation are operated with hydraulic joysticks and can be easily driven by anyone who is a beginner.



### SPACIOUS INTERIOR & COMFORTABLE SEATS

The spacious interior and comfortable suspension seats enhance the comfort.



### RADIO, SPEAKER OPTIONS

Equipped Options with high-performance speakers and radios.



### CONVENIENCE OF MAINTENANCE

Front open tilting canopy has been applied to improve serviceability and accessibility.

# NO PROBLEM ANYWHERE AGRICULTURAL & CONSTRUCTION



**VOLKAN**  
SKID-STEER LOADERS





## EASY MAINTENANCE

# SERVICEABILITY

The upper and lower double door structure is designed to facilitate access to filters and oils. Designed to protect internal components with shock-resistant rear doors.

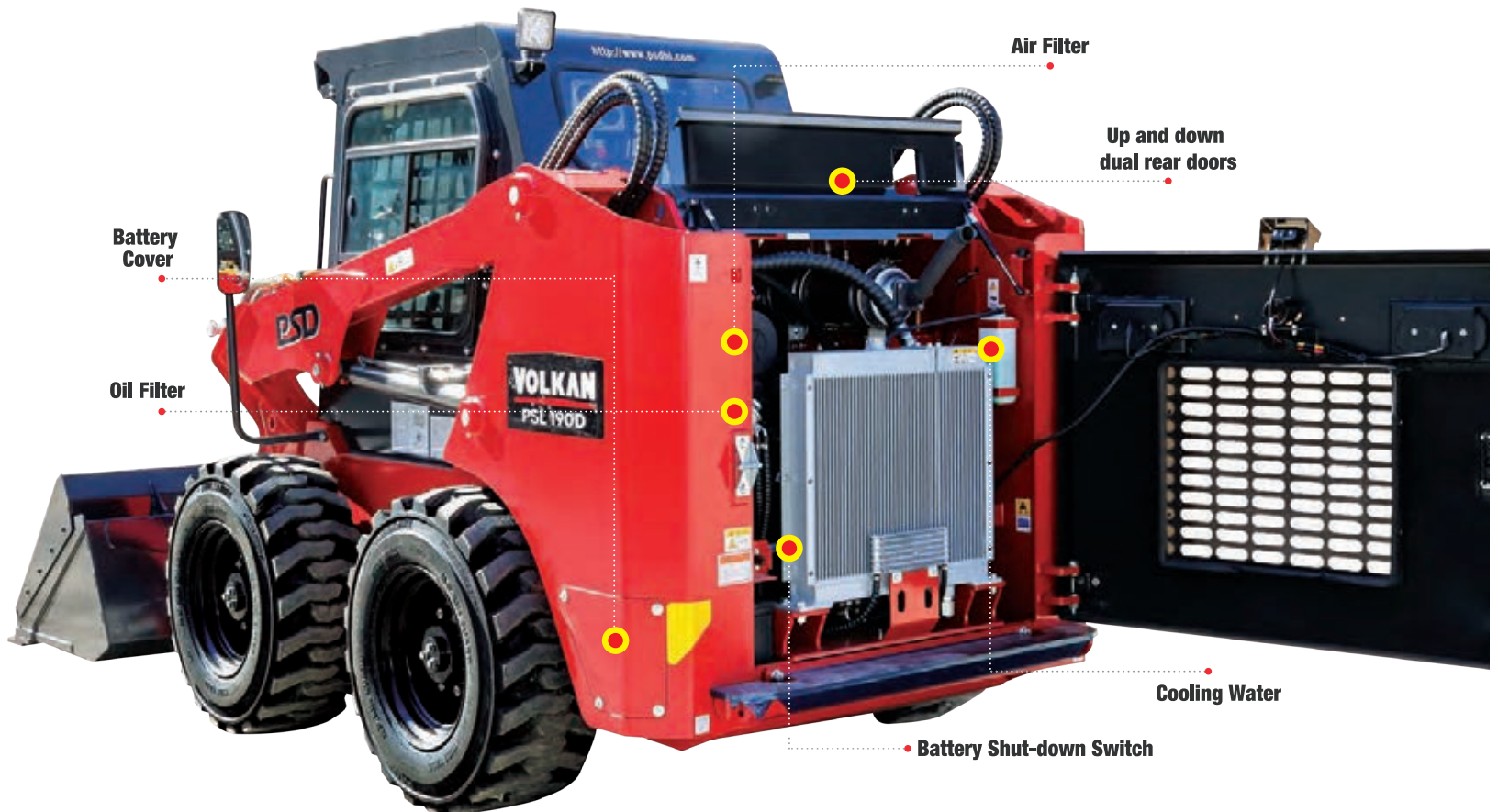

### TOP/BOTTOM DUAL REAR DOORS

Top and bottom dual rear doors for easy access to the inside of the machine



### FRONT-OPENING TILTING CABIN

Front-opening tilting cabin provides more space and easier access for maintenance work



### BATTERY CASE

Easy and simple detachable battery case for battery maintenance



### BATTERY SHUTDOWN SWITCH

Battery shutdown switch to prevent discharge during extended periods of inactivity



### HYDRAULIC GAUGE

Externally located hydraulic gauge for easy access



### BOOM DOWN VALVE

Boom down valve for safe, non-hazardous boom lowering for emergency maintenance

Transformers are here

# ANYTHING IS POSSIBLE



Large Bucket



Planner



Bale Clamp



PV Vibratory Roller



Short Auger



Angle Blade



Pallet Fork



Hydraulic Hammer



Wood Clamp



Oil Drum Clamps



Angle Sweeper



Industrial Grapple



Round Fork



Snow Blower



Crusher



Grapple Cutter

Hey cutting and removal



Pallet Fork

Lifting, handling, raising, moving objects  
warehouse organization, and more



Breaker

Mining, various demolition tasks



Mower

Grass cutting, weed removal, ground leveling



Excavator

Digging, moving soil&sand, various excavation tasks



Angle Blade

Snow removal and road clearance



Bale Clamp

Grabbing, lifting, raising, moving objects



Angle Sweeper

Road and floor cleaning, debris removal



Cold Planer

Road construction, maintenance, concrete  
and cement floor crushing

# SPECIFICATIONS

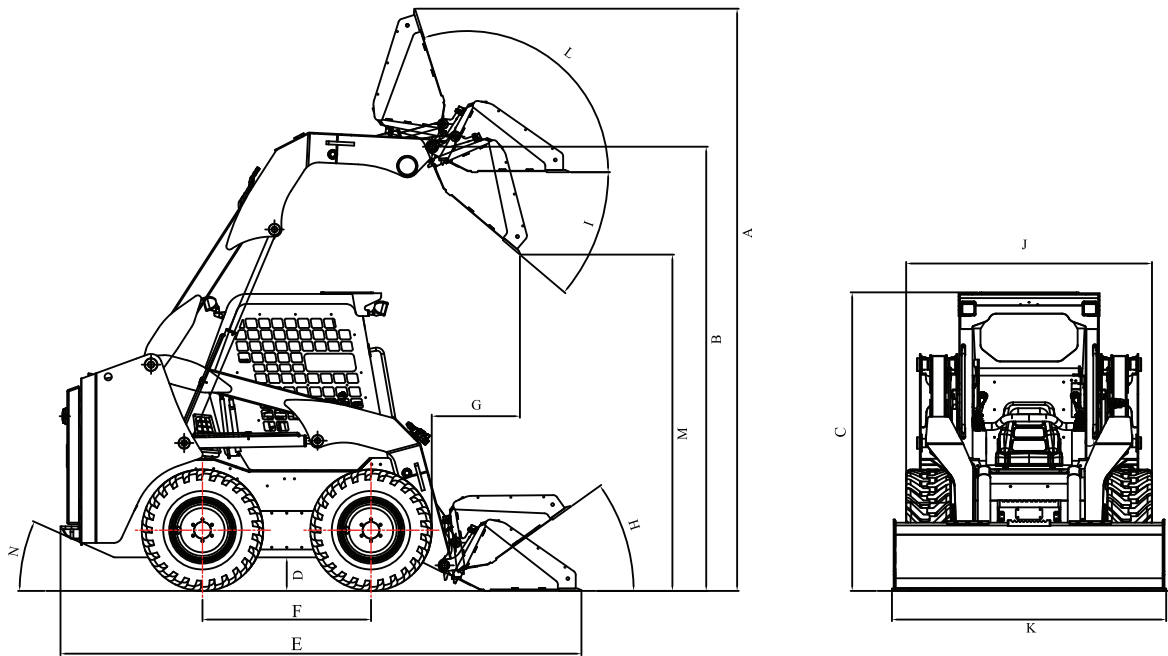

	Item	PSL150D	PSL180D	PSL190D
<b>Specifications</b>	A Overall Operating Height - Fully Raised	134.3" (3,410mm)	160" (4,065mm)	159.8" (4,060mm)
	B Height to Hinge Pin - Fully Raised	108" (2,740mm)	121.6" (3,090mm)	121.6" (3,090mm)
	C Overall Height to Top of Cabin	76" (1,930mm)	82.1" (2,086mm)	82.5" (2,095mm)
	D The lowest ride height	9.3" (235mm)	8.3" (210mm)	8.1" (206mm)
	E Overall Length with Bucket	120" (3,045mm)	136.6" (3,470mm)	145.3" (3,690mm)
	F Wheel Base	41.3" (1,050mm)	43.9" (1,116mm)	46.5" (1,180mm)
	G Dump reach at full height	21.3" (540mm)	17.9" (455mm)	24.8" (630mm)
	H Rollback at Ground	40.7°	29°	37°
	I Dump Angle	47.4°	43°	40°
	J Overall Width	60" (1,525mm)	64.5" (1,638mm)	70.6" (1,795mm)
	K Width ( with Bucket )	60.8" (1,545mm)	68.5" (1,740mm)	75.6" (1,920mm)
	L Maximum Bucket Angle	98°	98°	110°
	M Dump Height	83.5" (2,120mm)	90.9" (2,310mm)	91.3" (2,320mm)
	N Rear Bumper Angle	21°	20°	20°
<b>Engine</b>	Make	DAEDONG	DAEDONG	DAEDONG
	Model	4B243LWS	4HT5	4HT5
	Horse Power	50 HP	73 HP	73 HP
<b>Performance</b>	Rated Operating Capacity	1426.5 lb (647kg)	1962 lb (890kg)	2039 lb (925kg)
	Tipping Load	2855 lb (1,295kg)	3924 lb (1,780kg)	4079 lb (1,850kg)
	Travel Speed	11.2 km/h	11.5 km/h	11 km/h
	Operating Weight	4398 lb (1,995kg)	7165 lb (3,250kg)	7430 lb (3,370kg)
	Standard Tire Size	10 x 16.5	12 x 16.5	12 x 16.5

DAON GLOBAL, INC.  
3055 Wilshire Blvd. Suite 640  
Los Angeles, CA 90010

PRSR STD  
U.S. POSTAGE  
**PAID**  
LOS ANGELES CA  
PERMIT NO. 3377



**GLOBAL NETWORK**

Based on our initial commitment and fundamentals  
We're looking forward to the 21st century.  
It aims to grow as a world-class company.



**PSD HEAVY  
INDUSTRIES CO., LTD.**

**CONSTRUCTION EQUIPMENT AND AGRICULTURAL  
EQUIPMENT MANUFACTURING / SALES**

**HEADQUARTERS & FACTORY**

**Tel:** +82-53-353-7848 | **Fax:** +82-53-356-5313

**E-mail:** psd7848@naver.com

**Address:** 156 Chimsan-ro 67-gil, Buk-gu, Daegu-si, South Korea

**US BRANCH OFFICE**

**Tel:** +1-213-924-9722 | **E-mail:** support@daonglobal.net

**Address:** 3055 Wilshire Blvd Suite 640, Los Angeles, CA 90010

Visit our website:

[www.psdheavy.com](http://www.psdheavy.com)



@psdheavyindustireskoreavol4138